

J. J. Pearce Homeowners Association Newsletter

Website: www.jjphoa.org

April, 2004

News from the City

- The city is exploring rejuvenation needs and options for both the Heights and Huffines recreation centers, and needs in the northeast area of the city. Heights was built in 1965 and Huffines in 1978.
- The Rental Registration program is experiencing an estimated 90% compliance already. Over 1,700 properties have been registered across the city.
- Animals will only be required to receive rabies vaccinations every three years, and animal registrations will be extended to three years if the animal is vaccinated with a three-year rabies vaccine. The Texas Department of Health has revised its rules to permit the use of the three-year vaccine. Registration fees in Richardson remain among the lowest in the area. To view animals up for adoption go to www.cor.net/AnimalShelter/ and click on [Adoptable Animals](#).

Development proposal at Pearce — All JPHOA residents invited!

The J.J. Pearce Booster Club is proposing to build an indoor batting practice facility on the Pearce campus, between the two baseball fields. RISD has scheduled a meeting for residents of our Homeowners Association and The Reservation HOA to present the proposal and to solicit feedback. The meeting will be held in the Pearce High School cafeteria on **Thursday, May 6 from 6 – 7 PM**. We hope to see you there. If you are unable to attend you may share your thoughts with Development VP Chris Bruckner at 972-994-9374 or President Bernie Mayoff at 972-669-9169.

H.E.A.T. Registration and VIN Etching Event

The first H.E.A.T. Registration and VIN etching event of the year will be held on Wednesday, April 14th, 2004, from 9:00 a.m. until 2:00 p.m., in the parking lot of the main MCI building at 2400 N. Glenville Dr. at Greenville Ave. The North Texas Auto Theft Task Force also be on hand for the VIN etching portion

If the event is cancelled due to rain, it will be rescheduled for Wednesday, April 28th.

This service is FREE to the public, and an auto insurance discount will be available to owners who take advantage of the VIN etching.

Wildflower Festival!

This year's Wildflower Festival will be held over Mother's Day weekend, beginning at 6:00pm on Friday, May 7 and continuing until 8:00pm on Sunday, May 9. The Festival will again be held in Galatyn Park, around the Eisemann Center and the Fountain Plaza. Casual entertainment will include various street performers, the strolling wildflowers, a petting zoo, climbing wall, a singer and songwriter contest, a talent competition and other activities throughout the day.

Featured entertainers are expected to include:

Friday

Country singer Stephanie Urbina Jones (www.stephaniejones.net)
The Beatles Tribute Band (www.classicalmysterytour.com) with the Richardson Symphony Orchestra (www.richardsonsymphony.com)

Saturday

Gin Blossoms (www.ginblossoms.info) rock band
Cherry Poppin' Daddies (www.daddies.com) swing band
Blue Oyster Cult (www.blueoystercult.com) classic rock
Bad Company with Paul Rodgers (www.badcompany.com) classic rock
The Texas Instruments Jazz Band (www.enerjazz.com/jazz/tijb.html) and Fattburger (fattburger.com) jazz group

Sunday

Country artist Brian McComas (brianmccomas.homestead.com) and the Festival closes with radio station 99.5 The Wolf's Front Porch country music show.

Advance tickets for Richardson residents are \$5 per day. Tickets at the gate are \$10 per day for adults, including Richardson residents, so it makes sense to buy tickets in advance. A weekend pass is \$15 in advance or at the gate, and children's tickets are \$3 per ticket. Children under age 3 are free. Advance tickets are available only at the water department at City Hall from April 12 to May 6. There is a limit of six advance discount tickets per household and proof of residency is required. Watch for more information and schedules in Richardson Today and elsewhere, or check www.wildflowerfestival.com.

The Network of Community Ministries, an interfaith food bank serving the RISD area, will have a drop off booth and you are invited to bring three cans of food, or more, to donate.

Selling Richardson

Of course we each are ambassadors of the city where we live, and we expect realtors to sell the merits of our city too. But there are a few agencies whose *raison d'être* is to sell the merits of Richardson. The most well known of those agencies is the Richardson Chamber of Commerce.

Chamber of Commerce

The Chamber's focus is the growth and maintenance of economic development in the city of Richardson. The Chamber works with large and small businesses to help them understand the benefits of locating in Richardson, help them get started, and help them to succeed. The Chamber also works with commercial realtors and developers to foster the kind of development, and redevelopment, that the city would like to see. In fact a significant part of the Chamber's funding is provided by a contract with the City of Richardson to provide economic development services for the city.

Before the down turn in the communications technology business Richardson had the highest per capita property values, by a wide margin, of any city in Texas. Every high technology company in the world is aware of Richardson, Texas and the Telecom Corridor®. The Chamber even owns the registered service mark Telecom Corridor®. Almost 50%

of the land in Richardson is zoned for retail or other commercial business. Just as Addison citizens enjoy the tax benefits of the restaurant industry, Richardson has been fortunate to enjoy the tax benefits of a large concentration of interrelated high technology businesses. Hopefully the new TI plant which was recently announced, and which will be the largest wafer fabrication plant in the world, will spur recovery and a new round of growth in high tech occupancy and property values.

Last April the Chamber added a person to focus on retail development and redevelopment. Since then the Chamber has been gathering information about ownership, plans, alternatives and options for the 56 shopping centers in Richardson. Forty of these centers are located at major intersections, and the others are "in-between" locations. Now the chamber is on the verge of going out and working with commercial realtors and potential tenants to explore and promote additional retail opportunities in the city. One of the immediate efforts is the coordination of an election process to allow licensed Richardson restaurants to sell liquor without requiring club memberships. The Chamber does all this with a staff of about eleven people, which includes five devoted to Economic Development, and our own Pam Krause who runs the Leadership Richardson program.

Metroplex Technology Business Council

Complementing the Chamber, and sharing their building near the main post office, is the Metroplex Technology Business Council (MTBC). MTBC has an overlapping mission, but is focused on the high technology industry and not limited to Richardson. MTBC has a staff of an additional five people.

Chamber membership runs between 1,000 and 1,200, and MTBC has a membership approaching 300. Chamber membership is open to everyone doing business in Richardson, with dues varying by the size of the business. A variety of programs are held throughout the month, tailored to the needs of the various membership constituencies. More information is available at www.telecomcorridor.com/.

Convention and Visitors Services

Richardson Convention and Visitors Services (CVS) is a department within the city, reporting to the Assistant City Manager for Administrative Services. Their primary mission is to market Richardson as a destination for conventions, meetings, reunions, sporting tournaments and other groups. A secondary mission is promoting Richardson events such as the Wildflower Festival and the Art Festivals.

The Convention and Visitors Services department was formerly known as the Convention and Visitors Bureau and was part of the Chamber of Commerce. State law has specific restraints on what a Bureau can do and how it can be funded.

(Continued on page 3)

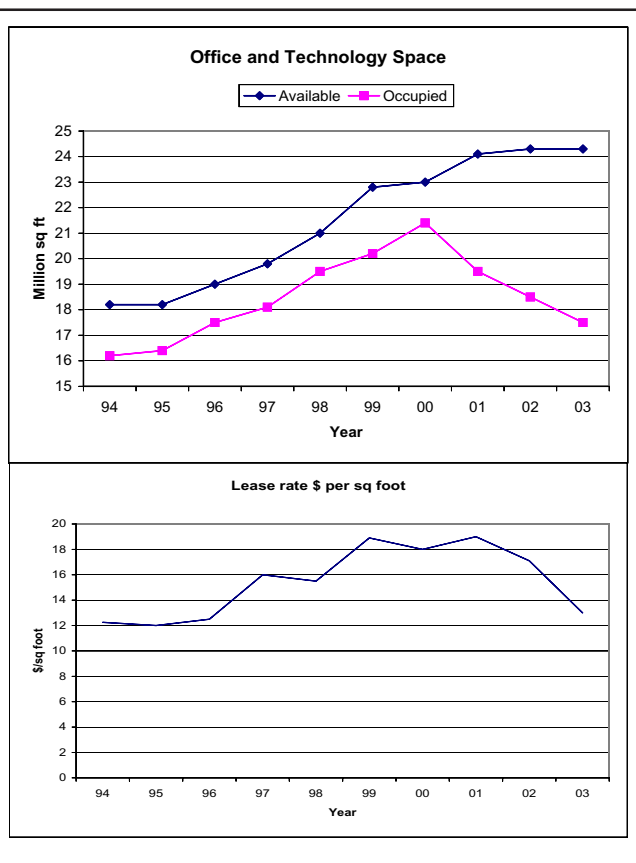

Factors that affect property values and taxes

(Continued from page 2)

With four full service hotels, the Eisemann Center and the Civic Center, and an increased focus on local events the city elected to move the department and its three employees directly into the city to provide additional flexibility. Although competition from other Metroplex cities is challenging, especially with the April opening of the Gaylord Texan Resort & Convention Center on Lake Grapevine in Grapevine, Richardson is positioned to host a variety of conventions, especially those which can take advantage of the Eisemann Center or proximity to UTD or the Telecom Corridor®.

Among the conventions that CVS efforts have helped to schedule for 2004 are:

- Sweet Adelines (1,500 people)
- Spring Classic Soccer Tournament
- National Association of Retired Federal Employees
- National Singing Quartet Convention (1,000 people)
- Society of Barbershop Quartet Singing (1,800 people)
- Texas Bankers Association
- Texas Accordion Association (200 people)
- National Collegiate Wrestling (500 people)
- Director's Choice Band Festival
- Assemblies of God – Gulf Latin District (600 people)
- Baptist General Convention of Texas
- Texas Cup Soccer Tournament

If anyone is involved in a group that has conventions, meetings or for any military or family reunions that you might want to host here in Richardson the Richardson Convention & Visitors Services would like to offer you planning assistance if you'll contact them at 972-744-4034.



RICHARDSON
Bike Mart
www.bikemart.com

Richardson
1451 W. Campbell Road, Richardson, TX 75080
Telephone 972-231-3993
Toll Free 1-800-600-3993
Fax 972-234-5724

Dallas
9040 Garland Road, Dallas, TX 75218
Telephone 214-321-0705
Fax 214-320-8666

Frisco
8820 John Hickman, Frisco, TX 75035
Telephone 972-335-7600
Fax 214-619-0765

Congratulations North Junior High

Congratulations to North Junior High faculty, students and parent on being recognized for sustained high performance in the period 2001-2003 by the National Center for Educational Accountability, www.nc4ea.org and www.just4kids.org. North was recognized in the areas of Reading, Mathematics and Social Studies.

Care packages for our troops in Iraq are still needed.

The response to the request in the March newsletter has picked up in recent days with contributions from a number of Association members. We thank all who have responded. Although we are encouraged, more is needed. Please try to find a few minutes in your busy day to provide at least one of the items listed below for the soldiers who are still serving in Iraq. Any items will be greatly appreciated.

Items below are most requested and hardest to come by.

***Baby Wipes *Girl Scout Cookies *Batteries (any size)**

Some other items they'd like are listed below.

***Beef Jerky *Cookies *Trail Mix *Chips**
***Mixed Nuts *Instant coffee**
***Chocolate Candy (in sealed packages)**
***Playing cards *Music CDs (copies ok)**
***Sun Glasses *Gun or military magazines**

You may contact any of the four people below to contribute.

Bernie Mayoff at 1411 Huntington, 972-669-9169
Joe Russum at 1102 Pueblo, 972-235-1961
Jerry Gray at 1115 Eton, 972-231-9206
Lynn Sanders at 1128 Grassmere, 972-231-6890



**PLUMBING
HOMEREPAIR
HOMEMAINTENANCE**

**PROFESSIONAL HANDYMAN
SERVICES**

(972) 985-4415

e-mail: brian@bradleygroup.com

BRIAN BUCHAN
Fully Insured
Over 20 years experience

Repair/replace - Install - Pick-up, Delivery, and Assembly

Gift Certificates Available



New wheels for RPD

Last month we described the rejuvenated police bicycle unit (www.jjphoa.org/news/, page 2), and their need for an additional bicycle. On behalf of our Association the Board decided to purchase that bicycle in conjunction with the Richland Park Homeowners Association and the assistance of Richardson BikeMart. The Board is shown presenting the new, small frame bicycle to Officer Stefanie Reim. Pictured left to right are Nancy De La Garza, Marc Perlstein, Dee Russum, Phil Meeker, John Sadowski, Stefanie Reim, Chris Bruckner, Thom Pomella, Richardson BikeMart manager Woody Smith, Bernie Mayoff, Captain Rhonda Bonner, and Richardson BikeMart owner Jim Hoyt. (Helen Simon is not pictured.)

Dallas Central Appraisal District Community Relations Officer to Speak

Thursday, April 29, 7:00 pm
 Faith United Methodist Church
 Corner of Old Campbell Road and Nantucket

The Greenwood Hills Neighborhood Association is sponsoring this meeting and invites any of our homeowners to attend. The speaker will be a representative from the Appraisal District, Cheryl Jordan. Ms. Jordan will give a brief overview of the appraisal process and the protest process for our homes. A question and answer period will follow

To assure there is enough seating, please RSVP at ghna@hotmail.com or 972-672-7390 before April 29 if you plan to attend.

Mohawk News

The entire third grade passed the TAKS test on the first try. Congratulations!

Fourth grader Camille Brewer was awarded second place at the North Dallas Regional Science Fair for her project, "Plants that Stand Tall 'til Acid Rain Falls". Sixth grader Stephen Boyd received third place for his project, "How quickly do gases from household hazardous liquids escape from the landfill. . . finding which household pollutants can cause air pollution." The North Dallas Regional Science Fair includes science fair winners from Allen, Carrollton, Plano, Garland, Richardson, McKinney and Mesquite school districts.

Mohawk Garage Sale
Saturday, April 17
starts at 8 AM

Out of sight, out of mind?

Recreational vehicles include motor homes, trailers, campers, 5th wheels, boats and similar equipment. Some people don't like the way they look when they're visible from the street, especially in areas with front-entry garages. Complaints over the years prompted a City Council subcommittee, and the city staff, to examine the magnitude of the problem, and to develop options for addressing the problem — if a problem exists. And then the Council asked the City Plan Commission to review the staff report and offer an opinion.

The hard part is determining if a problem exists at all. In an urban environment how much should one person's esthetic preferences be able to control another person's use of their property? When do someone's preferences become so unpleasant for a community that the City should legitimately impose restrictions? Is it fair to require that recreational vehicles be screened from view from the street at homes that have no rear entry driveways? Is it fair to tell people who acquired and park recreational vehicles in their driveways in conformance with the laws at the time that they can no longer do so? Is it fair for neighbors to have to look at recreational vehicles that are parked on front entry driveways? Those are the challenges that the City Plan Commission was asked to consider at a March 16 meeting .

Presidents of at least six Homeowners Associations were in the audience during the public hearing. Only one Homeowners Association commented on the situation at all, and that was to state that while RV parking was considered a small problem in their area, it was a small, low priority problem. No one else in the audience spoke in favor of imposing new restrictions, but about a dozen people spoke in opposition to making any significant changes to current regulations. Virtually everyone was in favor of strictly enforcing current ordinances. There was some discussion about easing parking restrictions for a recreational vehicle on the street temporarily while preparing for use or when returning home. The City Plan Commission will revisit that topic at another meeting on April 20.

Current regulations require that all vehicles be parked on a permanent driveway, not on grass. No vehicles are permitted to block a sidewalk at any time. No vehicles are permitted to interfere with visibility near a corner. There are also restrictions on the parking of commercial vehicles. To quote one member of the Commission: "What problem are we trying to solve, and if there is a problem, will we know if we've solved it?"



Minutes of Board Meeting, February 29, 2004

Bernie Mayoff called the meeting to order at 7:05 p.m. at the home of Thom Pomella. In Attendance: Bernie Mayoff, Thom Pomella, Dee Russum, Chris Bruckner, Mark Perlstein, and Nancy De La Garza

Minutes of Previous Meeting

- The minutes of the last Board meeting were approved as presented.

Treasurer's Report

- Bernie Mayoff presented the Treasurer's report on behalf of Helen. It was approved as presented. It was noted that the finances are in very good shape.

Old Business

- The planning for the volunteer party is going well.

New Business

- Bernie reported he attended a Chamber of Commerce meeting regarding ideas about a city election for sale of alcohol in restaurants.
- The city police force is using bicycles. It was approved to purchase a bicycle for the police department as a gift. The cost is around \$1000.
- Thom reported he will obtain permits for the Independence Day parade. The parade will be held on Monday, July 5th.
- The city's Neighborhood Awareness program has an e-mail process that can be made available to groups of homeowners regarding code violations. The city requires one main contact for a group. An article will be placed in the March newsletter to determine interest.
- "Good Neighbor Award." Discussed using the newsletter as a way of publicly recognizing a good neighbor.

Committee Reports

- Membership: Marc reported 1 new member and we are now at 75% participation.
- Development: Chris reported the JJ Pearce High School is considering building an indoor batting facility. He also noted the city council is to vote on the antenna issue on March 8. There is a new retail store next to Albertsons, Cool Breeze.
- Newsletter: Dee reported one new advertiser for lawn service.
- Safety: Thom reported that recently a tool shed was broken into and items taken. There was one home burglary. The police have been issuing tickets for stop sign runners in the neighborhood.

The next Homeowner's Association President's meeting will be March 16 at 7:00 a.m.

Next Board meetings are as follows.

- March 28, Planning session. Labels will be done March 31.
- April 4, 4:15 p.m. following volunteer reception at Helen's home. Newsletter deadline is April 2. The meeting adjourned at 8:15 p.m.

Respectfully Submitted,
Nancy De La Garza, Secretary

CRIME/SAFETY TALK
By Thom Pomella, VP Safety

RECENT CRIME

We had another burglary this month. I don't like this trend. Be alert. Be nosy. If you hear some strange noise outside, take a look. Do not hesitate to call the police on suspicious activity. They are there to help us.

On 3/11, around 1 PM, an unoccupied home in the 1300 block of Chesterton Drive was burglarized. Officers responded to an alarm call at the location and discovered the offense. The suspects were already gone. Entry was gained when the suspect(s) removed a windowpane from the overhead garage door, pulled the emergency release cord, and lifted the door. The wooden door into the house was also forced open. A dresser drawer was missing (probably used to carry property). Jewelry and electronics were taken. Although uncommon, the emergency release cord is an opportunity used by some burglars to gain entry into homes. If your garage door release cord is within arm's reach of a window when the door is in the down position, we recommend that homeowners "blank out" (replace with solid material, or mesh) the center windows near the cord. Another option is to tie up the cord so it no longer dangles at the window.

ACCIDENT AT MOHAWK ELEMENTARY

Did I get your attention with that headline? *Good.* Now I need everybody to read this article *before* there is an accident at Mohawk Elementary.

During the morning drop off and afternoon pickup of children, there are some parents doing some very dangerous things. There are some who park on Mimosa and then pop the door open on the street side to unload and load their children. There are those who just cross the street anywhere they want, ignoring the crosswalks. Some make illegal turns into and out of the school circle drive. There are people who park their car in the middle of the alley and walk their children to the school. People even use the private circle drives of the homes on Grassmere to park and to make u-turns. Those are private driveways, not public streets. There are people driving and talking on their cell phone, or looking at the child in the back seat. Stop it. Pay attention to your driving. There are children walking home and you need to watch out for them. Stop for the stop signs. Really stop and look, don't just slow down and roll through the intersection. If you drop off and pick up your child at Mohawk... please... Safety First. This behavior is an accident waiting to happen.

I have included in this article the 'Traffic Safety Guidelines' sent home by Mohawk Elementary. It includes a traffic pattern flow map.

Traffic Safety Guidelines
Effective January 6, 1999

Mohawk Elementary has established strict traffic safety guidelines to ensure the safety of all school children. This safety brochure is designed to outline those guidelines, and to clear up any confusion that you may have.

The Mohawk Safety Action Team has formulated traffic safety guidelines for all transportation means used by Mohawk students. These guidelines are designed to provide **MAXIMUM SAFETY FOR ALL STUDENTS.**

ARRIVAL & DISMISSAL TIMES:

School hours for grades 1-6: 8:00 am to 3:00 pm.
Kindergarten hours: Morning section: 8:00 am to 11:00 am
Afternoon section: 12:00 noon to 3:00 pm.

DRIVER'S GUIDELINES:

Basic School Zone traffic laws and traffic signs, designated by the City of Richardson and the Texas Dept. of Public Safety, apply at all times:

- Maximum speed limit: 20 m.p.h.

RULES OF THE ROAD

One-way traffic flow around the school grounds is to be observed during school "rush hour" (7:30-8:15 am and 2:30 - 3:15pm):

- All vehicles should approach the school from the south and enter the circle drive with a right-hand turn.
- **A left turn from southbound Mimosa into the drive is illegal during peak traffic times.**
- Drivers coming from the north should select an alternate route to accommodate an approach from the south.

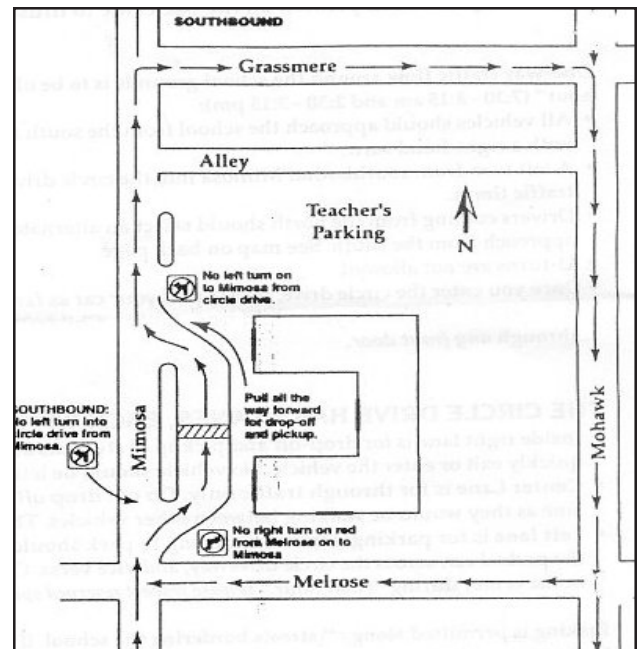

(Continued on page 7)

(Continued from page 6)

- U-turns are not allowed.
- Once you enter the circle drive, please pull your car as far forward as possible. The Safety Patrol will assist your child from the car. **Children may enter the building through any front door.**

THE CIRCLE DRIVE HAS 3 LANES, EACH WITH A PURPOSE:

- **Inside right lane** is for drop-off and pickup of students at curbside. Students should quickly exit or enter the vehicle. No vehicle should be left unattended in this lane.
- **Center lane** is for through traffic only. Do not drop off or pick up children in this lane, as they would be walking between other vehicles. **This is extremely dangerous.**
- **Left lane** is for parking. Drivers choosing to park should escort their students from the parked car, across the circle driveway, and vice versa. **Cross only at the crosswalk in the center** during “rush hour.” (Please respect reserved spaces.)

Parking is permitted along all streets bordering the school. If you have parked anywhere that requires students to cross the street or circle drive, cross at the designated crossing areas and escort your children all the way across the streets and driveways. **USE THE CROSSWALK CROSS GUARDS.**

TEACHER'S PARKING LOT

There is no drop-off or pickup in the teacher's parking lot at any time.

5th & 6th GRADE STUDENTS ONLY may be dropped off on Melrose in the morning and enter the building via the side door. Drop-off may occur between the signs for “BUS UNLOADING.” **Do not drop-off at the corner.**

F.Y.I.

THE REARWARD VIEW WITH MIRRORS

When do we rely on our mirrors the most? Probably when we are changing lanes. Our objective is to change position

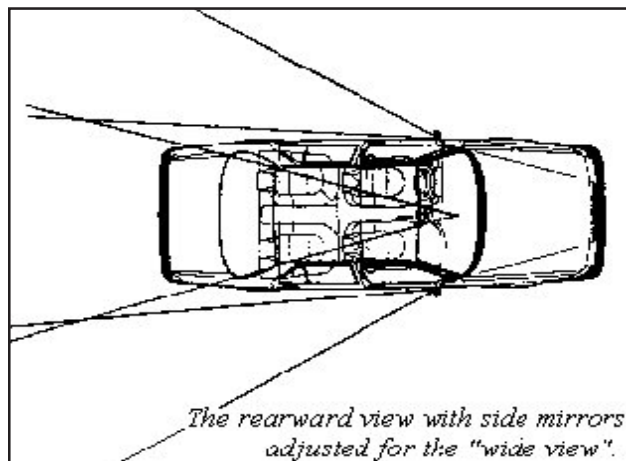

without getting in another driver's way or cutting him/her off.

The positioning for the inside rearview mirror is fairly obvious — you should be able to see out of the rear window. Be sure the day/night switch found on most rearview mirrors is in the day position during daytime operation

As for the side view mirror or mirrors, most people adjust them so they can see the side of the car on the inside edge of the mirror. Consider the view when the side view mirrors are set up as just described. Essentially, you have created “tunnel vision” to the rear. Your side view mirrors overlap much of what your inside rearview mirrors sees and you've also created blind spots.

What is the solution to tunnel vision and blind spots? Simply adjust the side view mirrors just beyond the point where you could see the side of the car on the inside edge of the mirror. With this setup, you almost completely solve the blind spot problem.

For the case where there is a vehicle present that isn't visible when checking the mirrors, the vehicle's position will probably be such that its front is adjacent to your door and you'll spot it in your peripheral vision as you check the side view mirror.

Most of us have dealt with blind spots by turning our head for a quick check. This isn't generally a problem in terms of missing something ahead; however, there can be a dangerous side effect. Unless you've worked to control it, your arms will move in the direction your eyes are looking causing the steering wheel to turn. With well-positioned mirrors, your head won't have to turn as far to check any remaining blind spots.

There are other applications of changing lanes that this setup is useful for as well. For example, when getting on a highway, your ability to judge how to best merge with the traffic flow will be greatly enhanced with the view provided by the “wide view” side mirror.

Likewise, as you pass interchanges on the highway, your ability to monitor traffic entering the highway is enhanced.

And finally, a good guideline for deciding when to move into the passing lane or back into the traveling lane is to make sure that you can see the headlights of the vehicle you want to pull in front of in the rearview mirror. We can all appreciate the value of adequate pull-in space.

Please - reread and remember the safe way to drop off and pick up your child at Mohawk.

Antenna tower approved

The City Council approved the T-mobile antenna tower that will be located in the middle of the Pearce campus. Cingular plans to use the stealth tower as well. The tower will be designed to accommodate a total of four carriers, although a current city ordinance limits the tower to three carriers. The ordinance is expected to be amended to permit a fourth carrier. The pole, the associated equipment, and the brick enclosure should be constructed within the next several months.

See the article on page 11 of the January newsletter for more information and illustrations, or see the newsletter on our website, www.jjphoa.org/news/news2004/01jan2002.pdf, for color renditions.

Greetings from VP Beautification, Phil Meeker

What's going on now – April Spring!

Emerging plants lift the soil springing forth, April fills our gardens; wild flowers and blooming trees are alive with migrating birds. The weather warms to a safe degree and almost anything can be planted here after April 15.

What to do now:

- Plant tender annual seeds – celosia, cleome cocks-comb, feathery cypress vine, purple hyacinth vine, marigolds, morning glory and zinnias.
- Vegetable seed – cantaloupe, cucumber, okra, peppers, pumpkins, squash and watermelon.
- Plant all variations of growing bedding plants that are purchased as 6 packs and 4" pots or larger. Reminder: gently pull apart roots to help develop a better root system for stronger plants.
- Now also is a good time to plant ferns, Hostas and all salvias (both annual and perennial).
- Container grown shrubs – can be planted year round if properly watered after planting, because of anticipated heavy April rain it is a good time to plant.

Cultivate:

Spring weeds easily pulled after rain and toss – Don't compost.

Fertilize:

New bedding plants – wait till they show some growth, usually about two weeks after planting.

Vegetables – a balanced blend of organic or chemical every 4-6 weeks.

Acid loving plants – Azaleas, camellias, hydrangea, applied after blooming. Add 2"-3" of mulch to help insulate root system from approaching heat.

Lawn – mow and fertilize as grass turns really green.

Control:

Thrips, mealybugs (look like mini cottonballs), and aphids (watch for shiny sticky leaves and black waste droppings). Release lady bugs (they really work) at the base of plant at sundown.

Design – Two commonly and important asked questions at nurseries and garden centers.

Q. How many bedding plants (of the same variety) do I need for a full effect?

A. Learn the growth habit of your selections.

Q. I want a nice small shrub – a statement, but still a question

A #1. When fully mature how high, wide do you require?

Evergreen, deciduous flowering? How much of your time do you want to nurture this plant?

A #2. Do some research before going to the Garden Center

Celebrate:

Take some weekend time off! Visit Farmers Market and buy locally grown fruits and veggies and pack a picnic lunch and spend at least a half day at the Dallas Arboretum – what a pleasure and learning experience, especially in the spring.

Don't forget to feed those migrating birds!

Master Gardeners Workshops

Master gardeners are volunteers trained at Texas A& M horticultural school to work with county horticulturists agents. Our Dallas county agent is located in the county government building on Marsh Lane at Walnut Hill Lane. Their offices are located in the basement. Among other things, you can apply for a passport in the same building.

On Sunday March 21, I attended their workshop on "Natural Beauties" – a guide to native and adapted and drought tolerant plants that thrive in Dallas with minimal watering. There were about a dozen attendees and sadly, only a dozen handouts. Categories from trees down to ground cover, along with cultural requirements are in this handout. To get a copy or if you have plant problems to "cure" call the county horticulture agent help desk, Monday – Friday 8:30 am – 4 pm at 214-904-3053. They can really help.

YARD OF THE MONTH begins in May!

**Election Day
Primary Runoffs**

April 13

Landlocked?

Try Greenwood Hills Community Club

By Chris Bruckner, VP Development

Looking for a great way to cool off this summer and relax with family and friends? Greenwood Hills Community Club is seeking new members for the 2004 season. This establishment, located at 1501 N. Waterview (NW Corner of Melrose and Waterview), is a non-profit corporation managed by an elected Board of Directors for the enjoyment of the entire community. Amenities include a swimming pool that is staffed by a lifeguard at all times, a wading pool for youngsters, a sand volleyball court, basketball, tetherball and video games. Members are welcome to bring food and drink for a great meal on the gas barbecue grills although vending machines are also available. For your enjoyment, portable radios and TVs may be brought in but family pets must remain at home. The Club is open every night till 9 PM and private parties are available after hours for an additional fee. New membership applications are located on the fence by the front gate or on their website at: <http://www.ourpool.org>. Questions? Contact Blake Whitaker, Membership Director, at 972-234-6965 or surf on over to their website.

Mobility 2025 update approved

On January 8 the Regional Transportation Council approved the latest Metropolitan Transportation Plan for North Central Texas. The plan, referred to as Mobility 2025, helps guide the expenditure of \$45,000,000,000 in federal, state and local funds expected to be available for transportation maintenance and improvements through 2025. Because the Metroplex has been designated by the Environmental Protection Agency as a non-attainment area for ozone pollution, the Plan must be updated every three years. The next update to the Mobility Plan is expected to be adopted in 2007.

The Plan documents where improvements to existing transportation can be expected and indicates where new facilities will be warranted based on population growth and travel patterns. Plan development is guided by federal legislation regarding the funding and construction of metropolitan transportation projects. It is a cooperative effort among local cities and DART, DFW Airport, Denton County Transportation Authority, Fort Worth Transportation Authority, North Texas Tollway Authority, Texas Commission of Environmental Quality and TxDOT.

A more comprehensive discussion of Mobility 2025 is available in the January 2004 issue of this newsletter, beginning on page 3. The newsletter is available on our website at www.jjphoa.org.

Chill out in the shade at Cool Breezes & The Blind Spot

By Chris Bruckner, VP Development

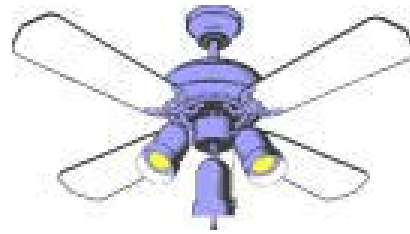

JJPHOA residents are fortunate to have new tenants occupying the space at 1335 W. Campbell Rd. as we welcome Cool Breezes & The Blind Spot into our neighborhood. They're right next to Pavillion Barbers. As you may have guessed from their dual name, this business sells both residential and commercial ceiling fans and window blinds.

Owner Carla Kay Whitehead and General Manager Brent Crandall have built a full service business based upon quality merchandise that is supported by a knowledgeable staff through continuous training. With a base of nearly 4800 clients, they proudly explain how Cool Breezes & The Blind Spot can readily continue operations without a single new customer to walk in the entrance. In fact, a large number of Recreational Vehicle (RV) owners travel far and wide to shop with them, but it's the opportunity for growth from pedestrian traffic that led them to relocate from Plano Rd. and Arapaho.

Founded out of her home in 1989, Ms. Whitehead now employs a staff of 7 who have built the company's reputation by providing a complete compliment of services including parts, installation, repair and cleaning. They'll even restore your antique fans and have several on display for sale. In the past, you may have noticed their advertisements in the Yellow Pages and radio broadcasts, areas they continue to explore for growth.

Cool Breezes & The Blind Spot is eager to pass along manufacturer sale to the consumer and all members of the police/fire/military receive a 5% discount at all times. Take advantage of these same great savings as JJPHOA homeowners when you bring this article into their store during your next purchase! Why don't you let the good folks at Cool Breezes & The Blind Spot help you beat the heat this summer and pay them a visit?

Cool Breezes: 972-690-4580

The Blind Spot: 972-644-9411

8 AM - 6 PM, Monday - Saturday

S. A. L. T. Seminar

In February several members of the Homeowners Association attended a S. A. L. T. seminar at Brookhaven Community College.

S. A. L. T. stands for Seniors And Law Enforcement Together. We learned of this through an e-mail from John Corbitt, the Crime Prevention Officer of the RPD. It lasted most of the day and was very informative.

We heard information ranging from General Crimes from a Texas Ranger with the Department of Public Safety, to the Process of Crimes of Victims and Specialized Crimes, given by a very knowledgeable representative of the District Attorney's office, to Living Trust Scams and Telemarketing Scams, and finally a talk on Identity Theft from a Social Security agent. This information is relevant for those who are not yet senior citizens as well.

One very important piece of literature we were able to pick up was a handy list of important Hot Line Numbers. (It is reprinted below.)

These seminars are presented once each quarter and you can find one that you can attend in the future by contacting the S.A.L.T. Council Co-chair, Paul Zobisch at 972-248-2573 X 103. It will be well worth your time to try to attend one of these seminars.

Alcohol in restaurants – update

The Richardson Chamber of Commerce is coordinating an effort to permit Richardson restaurants to sell alcoholic drinks to diners without requiring a Unicard or other membership card. The first step is gathering enough signatures to call an election. Some time between March 29 and the end of May you are likely to be asked to sign a petition authorizing such an election. A little over 9,100 signatures of registered Richardson voters are required to hold an election. The number required is based on the number of voters that took part in the last gubernatorial election.

If the petition drive is successful then an election on this issue should be scheduled for September 11. If there is an election, and if the results favor the proposal, then restaurants would be able to simplify their paperwork, reduce their costs and simply their access to wholesalers. If there are not enough signatures, or if the proposal fails to pass, then residents and visitors will continue to need club memberships or Unicards to purchase wine or other alcoholic drinks in Richardson restaurants, and potential restaurants will need to continue evaluating those requirements in deciding where to locate.

Useful HOTLINE NUMBERS

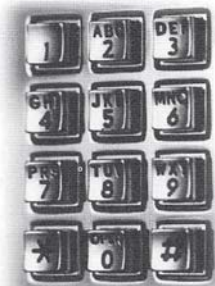

Office of the Attorney General

PUBLIC INFORMATION AND ASSISTANCE	800-252-8011
CHILD SUPPORT PROGRAM	800-252-8014
DEAF OUTREACH (TDD)	800-572-2686
CRIME VICTIMS' COMPENSATION PROGRAM	800-983-9933
OPEN RECORDS	877-673-6839
CONSUMER PROTECTION	800-621-0508

Criminal Justice

TEXAS CRIME STOPPERS	800-252-8477
TEXAS DPS—MISSING PERSONS	800-346-3243
TDCJ VICTIMS' SERVICES	800-848-4284

Child & Family Issues

NATIONAL MISSING/EXPLOITED CHILDREN	800-843-5678
TEXAS COUNCIL ON FAMILY VIOLENCE	800-525-1978
NATIONAL DOMESTIC VIOLENCE HOTLINE (TDD)	800-799-7233
CHILD AND ELDER ABUSE	800-252-5400
TEXAS RUNAWAY HOTLINE	888-580-HELP
TEXAS YOUTH HOTLINE	800-210-2278
TEXAS ASSOCIATION AGAINST SEXUAL ASSAULT	888-918-2272
WOMEN'S ADVOCACY PROJECT	800-374-4673

Consumer Protection

FEDERAL TRADE COMMISSION	877-382-4357
FTC IDENTITY THEFT	877-438-4338
TEXAS DEPARTMENT OF INSURANCE	800-252-3439
PUBLIC UTILITY COMMISSION	888-782-8477

Senior Resources

TEXAS DEPARTMENT ON AGING	800-252-9240
NURSING HOME OMBUDSMAN	800-252-2412
LONG-TERM CARE REGULATORY	800-458-9858

Access to Legal Services

FAMILY LAW HOTLINE	800-777-3247
LEGAL HOTLINE FOR OLDER TEXANS	800-622-2520
STATE BAR OF TEXAS	800-204-2222
LAWYER REFERRAL SERVICE	800-252-9690
GRIEVANCES AGAINST LAWYERS	800-932-1900
TEXAS RURAL LEGAL AID	800-369-0574

J J PEARCE HOMEOWNERS ASSOCIATION
Statement of Cash Receipts and Expenses
For the Period September 1, 2003 to March 31, 2004

	Month Ended March 31, 2004	Year to Date Actual March 31, 2004	Year To Date Budget
Cash Receipts			
Membership Dues	\$15.00	\$5,115.00	\$4,950.00
Dividends	16.89	76.40	70.00
Advertising-Newsletter	160.00	1,050.00	630.00
Contributions	5.00		
Total Receipts	\$191.89	\$6,246.40	\$5,650.00
Expenses			
Crime Watch			
Metrocall	21.85	152.95	152.95
Membership			
Annual Meeting		159.00	159.00
Binders			100.00
Board Planning Meeting	289.08	289.08	200.00
Directory Printing		526.97	320.00
Directory Delivery		30.00	30.00
Social Events			
December Decorations		64.44	125.00
Volunteer Party	28.67	28.67	275.00
Newsletter			
Printing, etc.	173.90	1,479.95	1,643.60
Delivery	60.00	435.00	450.00
Other Expenses			
Contributions		234.75	235.00
Federal Income Tax	13.00	13.00	25.00
Miscellaneous		4.20	57.75
Total Expenses	586.50	3,418.01	3,773.30
Net Income (Loss)	(-\$394.61)	\$2,828.39	\$1,876.70

	Checking	Vanguard	Totals
Beginning Balances - 3/1/04	\$1,124.35	\$18,747.41	19,871.76
Add receipts	175.00	16.89	191.89
Transfers			
Less Disbursements	586.50		586.50
Ending Balances - 3/31/04	\$712.85	\$18,764.30	\$19,477.15

Respectfully Submitted, Helen Simon, Treasurer, April 2, 2004



Ebby Halliday
REALTORS

Dorothy Thomas
REALTOR®
Multi-Million Dollar Producer
dorothyshomes@mindspring.com
7601 Campbell Rd., Ste 700
Dallas, TX 75248
Office: (972) 248-8800
Fax: (972) 248-6872
Mobile: (469) 233-3396
Residence: (972) 231-3396

www.ebby.com



BOB CAIN
Store Director

ALBERTSON'S, INC. / 1341 WEST CAMPBELL
RICHARDSON, TEXAS 75080 / 972-437-2896 / FAX: 972-437-5914

Local Events April - May include:

Date	Event	Time/Location
April		
2	Tennis vs. Richardson	4:15pm, Pearce
2-3	Gauguin's Paradise (original theater)	8:00pm, Univ Theatre, UTD
3	Classical Indian music concert	8:00pm, Conference Center, UTD
4	Gauguin's Paradise (original theater)	2:30pm, Univ Theatre, UTD
	Shostakovich, Tchaikovsky concert	7:30pm, UTD Conf Ctr
6	Softball vs. Poteet	5:30pm, 7:00pm, Pearce
7	Tennis vs. Poteet	4:15pm, Pearce
9	Snow makeup day	
9-10	Dance concert	8:00pm, University Theatre, UTD
12	Snow makeup day	
13	Primary Runoff Election	7:00am - 7:00pm, Mohawk
	Baseball vs Poteet	4:30pm, 7:30pm, Pearce
	Softball vs Wylie	5:30pm, 7:00pm, Pearce
17	Mohawk Garage Sale	8:00am, Mohawk
	JV Baseball vs. Richardson	7:00pm, Pearce
	Classical piano concert	8:00pm, UTD Conference Center
18	Rising Stars concert (free)	6:00pm, Jonsson Perf. Hall, UTD
22-24	Theater: "Noises Off" (see page 13)	7:30pm, Pearce
23	Baseball vs. West Mesquite	4:30pm, 7:30pm, Pearce
	Softball vs. Horn	5:30pm, 7:00pm, Pearce
24	Baseball vs. Coppell	1:00pm, Pearce
	Richardson Symphony Orchestra	Eisemann Center
25	Richardson Community Band pops concert	2:00pm, Eisemann Center
	Choral concert (free)	8:00pm, University Theatre, UTD
30	Baseball vs. Horn	7:30pm, Pearce
May		
1	Chamber Music Ensemble (free)	8:00pm, Jonsson Perf. Hall, UTD
1-2	Cottonwood Art Festival	9:00am-6:00pm, Cottonwood Park
6	Pearce Development proposal	6:00pm, Pearce cafeteria
7	Wildflower Festival (see page 1)	Galatyn Park, 6:00pm
8	Wildflower Festival (see page 1)	Galatyn Park, 11:00am
9	Wildflower Festival (see page 1)	Galatyn Park, 12:00pm
11	Spring Choir Concert	7:30pm, Pearce
13	Pearce Orchestra Concert	6:30pm at Pearce
22	Pearce Graduation Day	1:30pm Moody Coliseum, SMU
26	Mohawk 6 th grade graduation	7pm, Mohawk
27	School Ends	
30	Richardson Community Band Concert (free)	7:00pm, Civic Center
31	Memorial Day Holiday	
	Concert and fireworks	8:00pm Breckenridge Park
18	Richardson Community Band Concert (free)	7:00pm, Civic Center

For information on performances at UTD call 972-883-2982, or <http://ah.utdallas.edu>



Douglas R. Crosby
D.D.S., M.S.
Diplomate, American Board of Orthodontics

1920 N. Coit Road Suite 220 Richardson, TX 75080 972-680-9882

5509 Pleasant Valley Suite 40 Plano, TX 75023 972-867-0700

Orthodontics for adults and children

"Our Service Is A Cut Above!"

PAVILLION BARBERS



M-Sat 8-6
1331 W. Campbell Rd.
Richardson, TX
(972) 479-0840

Board of Directors 2003 —2004

President	Bernie Mayoff	972-669-9169	bernie@mayoff.com
VP Development	Chris Bruckner	972-994-9374	csmail@airmail.net
VP Safety	Thom Pomella	972-690-5980	thom@pomella.net
VP Beautification	Phil Meeker	972-690-4677	jmeeker@americorp.com
VP Membership	Marc Perlstein	972-907-9208	mperl112@aol.com
Secretary	Nancy De La Garza	972-783-6462	delern@aol.com
Treasurer	Helen Simon	972-234-2443	helen@simon-says.net (business phone)
Newsletter	Dee Russum	972-235-1961	ddrussum@comcast.net
Webmaster	John Sadowski	972-238-9826	jcsadowski@aol.com

Newsletter Advertising

Business ads must be paid for in advance. Checks should be made payable to J. J. Pearce Homeowners Association.
Contact Dee Russum, 1102 Pueblo, phone 972-235-1961 or e-mail: ddrussum@comcast.net

Rates per newsletter, based on 8 ½ X 11" page.

Business card (2 x 3 ½ ")	\$10.00
¼ page	\$20.00
½ page	\$40.00
Full page	\$75.00

Any business ad purchased for a full year receives a free ad in the directory.



Homemade Gourmet
"Bringing Families Back to the Dinner Table"®

Judi McGregor
Independent Distributor

Dist. #12617
972.470.0997
fax 972.907.9227
469.644.3503
cmcgregr@swbell.net

1216 Stratford Drive
Richardson, TX 75080

Phone: (214) 232-9898
Fax: (972) 234-5702
Email: b.christian@officemax.com

BRETT CHRISTIAN
Commercial Account Manager



Document Services
<http://ftp.copymax.com0431>
cmx0431@copymax.com

“Noises Off!”

The Pearce theater department will present its final production of the season at 7:30pm on April 22, 23 and 24. “NOISES OFF” is a delightful comedy about a group of actors trying to put together a play on the road so they can move it to the West End. The first act is the dress rehearsal, then the play moves into the second act where the actors are “on stage” and the audience is seeing the chaos happening backstage. The dates are April 22,23,24 at 7:30 pm. A complimentary dessert is included in the price of the ticket. All tickets are reserved seating and are \$8. Tickets are available by calling 469-593-5136 or going on line at www.pearcetheater.com.



J. J. Pearce Homeowners Association
1411 Huntington
Richardson, Texas 75080

Indoor batting facility proposal meeting. May 6, 6-7 PM See page 1 for details.

Board Meetings: May 2, 7:00pm, 1201 Grassmere
June 2, 1411 Huntington, 7:00pm
June 30, 1221 Huntington, 7:00pm

Board meetings are open to all members